



BW2

Wafer type butterfly valve

Butterfly valves for use in heating, cooling and ventilation systems.

- ✓ Size DN40...200
- ✓ Kvs value | 10...3120
- ✓ No leakage
- ✓ Pressure rating PN16
- ✓ Media temperature -20...+120°C
- ✓ Flange PN6/10/16

Function

The butterfly valve is used as a shut off valve or a control valve (10° - 70° opening). Manual operation is possible through a hand lever. Flow can be bi-directional.

Installation

The valve is bolted between two flanges.

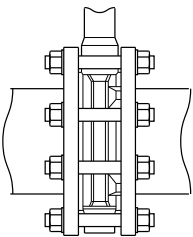

- ✓ Before installation of the control valve, ensure that the pipe is clean. Make sure that pipe scale, metal

chips, welding slag and other foreign materials are removed.

- ✓ For maximum efficiency and minimum wear, install the valve in a vertical position with the stem pointing upward. If the valve is mounted with the actuator on the side, more wear is caused to the valve stuffing box. The valve should never be mounted at an angle of more than 90°.

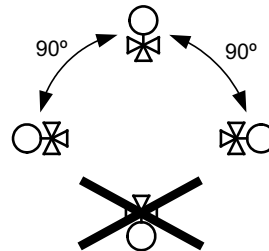

- ✓ Make sure there is ample space above the valve to facilitate easy removal of the valve actuator.

HEAD OFFICE SWEDEN

Phone: +46 31 720 02 00
 Web: www.regincontrols.com
 E-mail: info@regincontrols.com

BW2

- ✓ During fitting, the wafer butterfly must be open. The seat is constructed so that no additional seals or gaskets are necessary when the butterfly valve is fitted between the pipe flanges.
- ✓ Adjust the connection between the valve and the counter flange to minimise the tension between them.
- ✓ Tighten the bolts crosswise, as shown in the picture below. Tighten one flange at a time. After conducting a test run, the bolts should be tightened crosswise once more.

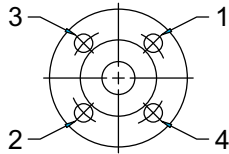

- ✓ Fit a strainer/filter upstream of the valve to prolong the equipment's life span.
- ✓ A water quality according to VDI 2035 is recommended.

Technical data

Application	Heating systems, cooling systems, ventilation systems
Pressure rating	PN16
Connection	Flanged according to EN 1092-2 / ISO 7005-2
Actuator mounting flange	ISO 5211
Flow characteristics	On/off (modulating possible between 10° and 70° opening)
Max. leakage	0 % of Kvs
Media	Hot water, cold water, glycol-mixed water (max. 50 % glycol)
Media temperature	-20...+120 °C
Max. flow speed	4 m/s

Material

Body	Nodular iron EN-GJS-450-10
Disc	Nodular iron EN-GJS-450-10 (Nylon coated)
Seat	EPDM
Stem	Stainless steel 1.4401
O-rings	EPDM

Models

Article	Kvs	Nominal diameter	Weight
BW240	110	DN40	2 kg
BW250	190	DN50	3 kg
BW265	315	DN65	4 kg
BW280	425	DN80	4 kg
BW2100	720	DN100	6 kg
BW2125	1240	DN125	8 kg
BW2150	1860	DN150	9 kg
BW2200	3120	DN200	14 kg

Combination options (valves and actuators) and diff. pressure

Article	ΔP_s (SR...) [kPa]	ΔP_s (GR...) [kPa]	ΔP_s (OM2...) [kPa]	ΔP_s (OM3...) [kPa]	ΔP_s (OM4...) [kPa]
BW240	1000 ¹	1600 ²	N/A	N/A	N/A
BW250	600 ¹	1600 ²	N/A	N/A	N/A
BW265	300 ¹	1600 ²	N/A	N/A	N/A
BW280	150 ¹	1400 ²	1600 ³	N/A	N/A
BW2100	N/A	600 ²	1600 ³	N/A	N/A
BW2125	N/A	N/A	1400 ⁴	1600 ⁴	N/A
BW2150	N/A	N/A	200 ⁴	1600 ⁴	N/A
BW2200	N/A	N/A	N/A	N/A	1600 ⁵

ΔP_s constitutes the max. permitted differential pressure at which the valve actuator can safely close against the pressure.

¹ With adapters VAR-SR + ZSV-11

² With adapters ZGI-002 + ZGV-16

³ With adapter VAR-OM2

⁴ With adapter VAR-OM3

⁵ With adapter VAR-OM4

Accessories

Article	Description
HL1	Hand lever for manual operation of BW2 valves DN40...DN100
HL2	Hand lever for manual operation of BW2 valves DN125...DN150
HL3	Hand lever for manual operation of BW2 valves DN200
VAR-SR	Adapter F05/F07, for SR-actuator
ZSV-11	Adapter 11x11x57 mm, for SR-actuator
ZGI-002	Adapter 11x11x20 mm, for GR-actuator
ZGV-16	Adapter 16x16x40 mm, for GR-actuator
VAR-OM2	Adapter 22 mm / 11 mm, for OM2-actuator
VAR-OM3	Adapter 22 mm / 14 mm, for OM3-actuator
VAR-OM4	Adapter 36 mm / 17 mm, for OM4-actuator

Dimensions

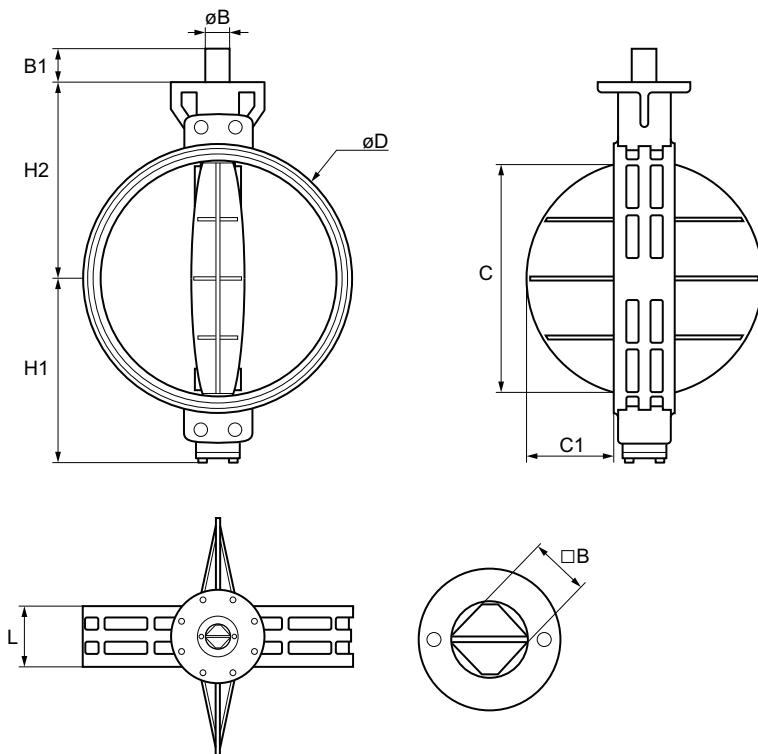

Size, DN	Size, inch	L	H1	H2	ϕD	C*	C1	ϕB	B1	$\square B$	Mounting flange (ISO 5211), type	Mounting flange (ISO 5211), PCD
40	1½	33	60	120	81	34	7	14	19	11	F07	70
50	2	43	65	143	96	39	8	14	19	11	F07	70
65	2½	46	71	155	110	55	13	14	19	11	F07	70
80	3	46	77	162	124	69	19	14	19	11	F07	70
100	4	52	107	181	148	91	27	14	19	11	F07	70
125	5	56	122	197	180	115	36	18	19	14	F07	70
150	6	56	150	210	206	140	47	18	19	14	F07	70
200	8	60	165	240	259	186	68	22	24	17	F10	102

* Make sure inside pipe diameter > C.

Measurements in mm unless otherwise specified

Pressure drop curves

Pressure drop

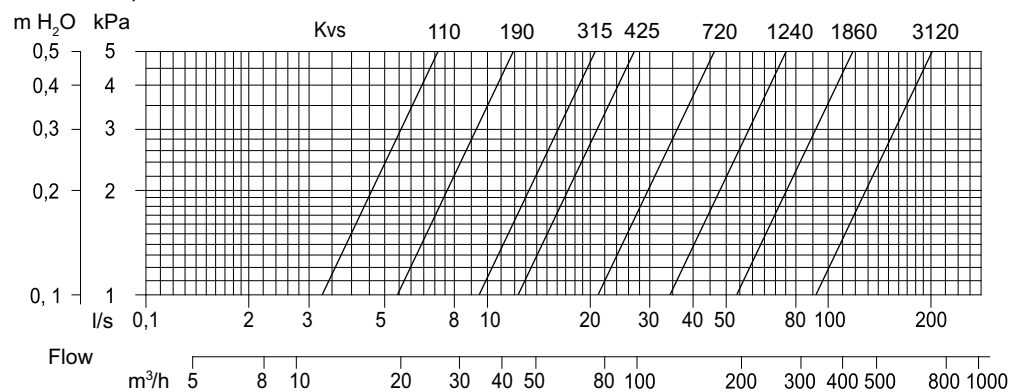

Example, pressure drop curves

If the pressure drop is 3 kPa (A) and the flow is 20 m³/h (B), a valve with the kvs value 110 (C) is preferably selected. See the markings in the picture below.

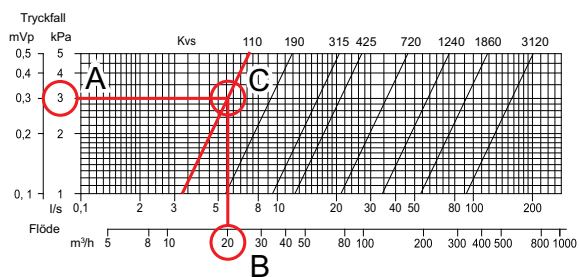

Product documentation

All documentation can be downloaded from www.regincontrols.com.